

TECH LETTER #7

NOTES ON DC POWER SUPPLY ISOLATION MEASUREMENT

HARRISON LABORATORIES
DIVISION OF HEWLETT-PACKARD CO.

100 Locust Avenue
Berkeley Heights, N.J.

NOTES ON DC POWER SUPPLY ISOLATION MEASUREMENT

As pointed out in section B14 of the H-Lab Power Supply Application Manual, it is desirable in some applications to operate a power supply floating -- that is, with both the positive and negative terminals separated from ground. This may be done (1) to elevate the output potential of the power supply, or (2) to reduce ground effect problems, or (3) because of the nature of the load device itself, which may require a power supply with neither output grounded (e.g. a bridge circuit with one of the two center arms grounded). Applications involving floating supplies often require an exact knowledge of the isolation properties of the power supply. This Tech Letter outlines methods which can be used in measuring these isolation properties.

Figure 1 illustrates schematically the equivalent leakage components normally used to define the isolation properties of a power supply.

1. R_G - Leakage resistance between output and ground.
2. C_G - Shunt capacitance between output and ground.
3. I_G - Noise current between output and ground.
4. C_S - Capacity between AC input and DC output.
5. V_B - Breakdown voltage to ground.

It can be seen that the circuit of Figure 1 is not a completely accurate representation of the stray properties which detract from the complete isolation of the ideal power supply. Indeed, it would be difficult to draw such an exact schematic. R_G , for example, actually is the result of the leakage resistance not only from the negative output terminal to ground, but also from the positive output terminal and all other points within the power supply rectifier and regulator. Similarly, C_S is comprised of the stray capacitances from all parts of the primary side of the power transformer to all points associated with the output portion of the power supply. Thus, Figure 1 is merely suggestive, not definitive; however, in the discussions which follow, it will be found that the measurement methods used join together appropriate input and output terminals in such a way that the circuit of Figure 1 reduces to the desired equivalent circuit for measurement purposes.

1. MEASUREMENT OF R_G - Figure 2A - LEAKAGE RESISTANCE BETWEEN OUTPUT AND GROUND

With the power supply de-activated, AC, ACC, and GND terminals are shorted together, and the (+) and (-) output terminals are shorted to each other. Between these two junctions the leakage resistance is measured with a megohmmeter (such as SIE Model C6-B).

Leakage resistance can vary greatly with relative humidity -- as much as several orders of magnitude. In making comparisons between the isolation properties of various supplies, it is therefore important that the same relative humidity be present for all such measurements.

2. C_G - Figure 2B - SHUNT CAPACITANCE BETWEEN OUTPUT AND GROUND

This measurement is made in exactly the same way as the measurement for leakage resistance except that an impedance bridge is substituted for the megohmmeter.

It is possible for the stray capacitance, C_G , to have a different measured value when the power supply is turned on. If C_G is measured while the power supply is activated, particular care must be taken that the DC output from the power supply does not flow through the bridge. Also, an oscilloscope should be used to check for the existence of ground loop currents which may influence the reading of the impedance bridge meter. It is suggested that the reader refer to section D1 of the H-Lab Power Supply Application Manual for methods of detecting and eliminating ground loop problems. Even after ground loops have been eliminated, the impedance null will probably not be as sharp as when C_G is measured with the power supply de-activated, since the power supply when activated injects some amount of noise between the output terminals and ground.

3. I_G - Figure 2C - NOISE CURRENT BETWEEN OUTPUT AND GROUND

This spurious noise source arises mainly from capacitance coupling to the chassis of points within the power supply circuitry having a large or high frequency potential. Because of the relatively small equivalent capacitances and high voltages associated with them, this noise source is usually represented as a high impedance or current source which injects noise from the chassis into the output terminals. This noise source may also be defined as the voltage appearing across a 1K resistor placed from either output terminal to ground while the power supply is activated in the normal fashion.

It is measured in just that way. An oscilloscope or suitable AC voltmeter is used to monitor the voltage across the resistor placed between the output terminal and ground. While a 1K resistor is most often used for this measurement, it is not uncommon to make similar measurements with a 100 ohm or 10K resistor. Of course, if I_G is truly a constant current source, then the voltage measured across 10K will be ten times larger than across 1K, etc. It is of interest in many applications to measure the RMS and peak-to-peak values of this noise source and to investigate variation of the noise source as a function of input line voltage and DC output voltage and current.

If the power supply and/or load circuit employs capacitors between the output terminals and chassis ground, it is probable that a simple linear relationship will not exist between the resistor R_M and the noise voltage measured across it. In this case, it will be necessary to specify the noise voltage from the output terminals to ground in terms of a specific resistance value rather than in terms of an equivalent current source, I_G .

4. C_S - Figure 2D - CAPACITY BETWEEN AC INPUT AND DC OUTPUT

This is also known as the transformer leakage capacity (usually the major portion of C_S) and as the transfer capacity. It represents the mechanism by which common mode signals on the AC line are coupled longitudinally to the output. C_S cannot be measured on an impedance bridge since it is not separable by such measurements from the other capacitances within the power supply.

Referring to Figure 2D, it can be seen that C_S is measured by injecting a signal generator voltage between chassis ground and the two shorted input terminals. The DC output terminals are shorted together and a resistor R_M is inserted between them and chassis ground. Inevitably, there will exist some stray capacity in shunt with R_M , and the measurement method may have to take the effect of C_G into account, depending upon the frequency of measurement and the values of the constants involved. A good starting point for this measurement is to use a 1K resistor for R_M . It is recommended that an oscilloscope be used to monitor the voltage across R_M , since in this way pick-up and other affects not related to the excitation from the signal generator may be eliminated or ignored. Alternatively, a voltmeter tuned to the same frequency as the signal generator may be used.

Using the equivalent circuit of Figure 2D, one can compute the value for C_S , knowing the values of R_M , C_S , V_X , and V_M . This can be somewhat tedious, however, and it is useful to adjust the input frequency so as to simplify the procedure.

If (1) $R_M \ll X_{C_G}$, and (2) $R_M \ll X_{C_S}$,

$$\text{then, } C_S \approx \frac{V_M}{V_X} \frac{1}{2\pi f R_M}$$

Condition (1) can be checked by verifying that in the interval of measurement V_M is proportional to f , the frequency of the applied excitation, and that V_M is proportional to R_M . Condition (2) will be met if condition (1) has first been satisfied and $V_X \gg V_M$. In order to satisfy these conditions and use the simple relationship for C_S given above, it may be necessary to adjust either R_M or f until a suitable combination is found.

As a final check that stray signals are not influencing the measurement, it should be verified that V_M goes to zero when V_X is reduced to 0.

5. V_B - Figure 2E - BREAKDOWN VOLTAGE TO GROUND

The two AC input terminals are shorted to ground and a high voltage tester is inserted between this point and the two DC output terminals shorted together. This high voltage tester should have a high source resistance so that when voltage breakdown occurs the detection of this effect does not result in destruction of the power supply insulation.

In most power supplies, the mica washer which separates the power transistor from the heat sink (ground) is the limiting factor which determines the breakdown voltage. Mica exhibits an insulation characteristic which is normally useful for 1000 volts for each one mil thickness. The mica washers employed in H-Lab power supplies are between 1.5 and 2.0 mils thick. Thus, it might be concluded that the supplies could be rated for 1500 to 2000 volts operation off ground. However, the presence of a normal amount of dust and impurities, plus a conservative engineering attitude, make it impractical to rate power supplies for operation above 300 or 500 volts off ground. However, special factory modifications in many cases will permit operation at still higher potentials.

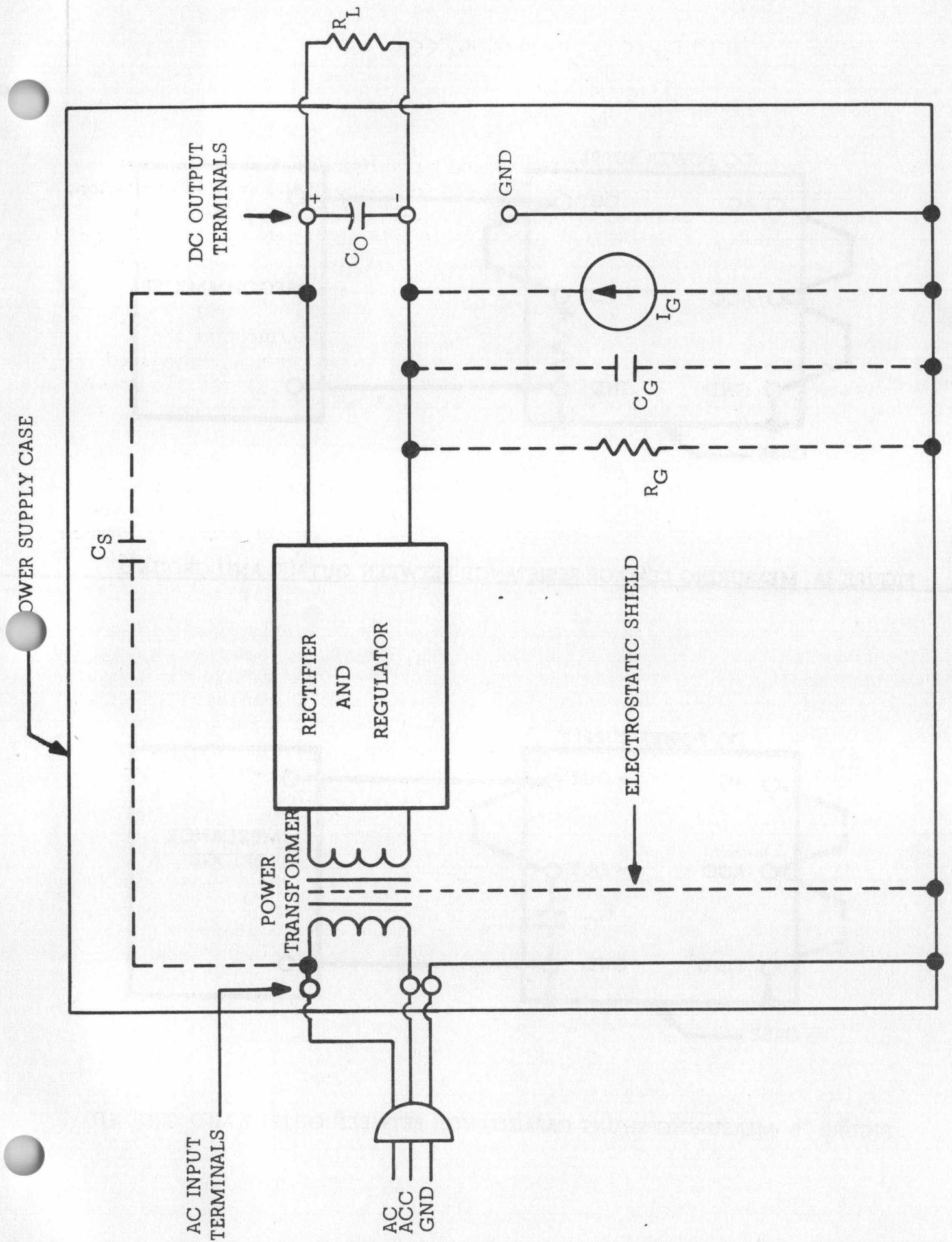

FIGURE 1 POWER SUPPLY LEAKAGE PATHS

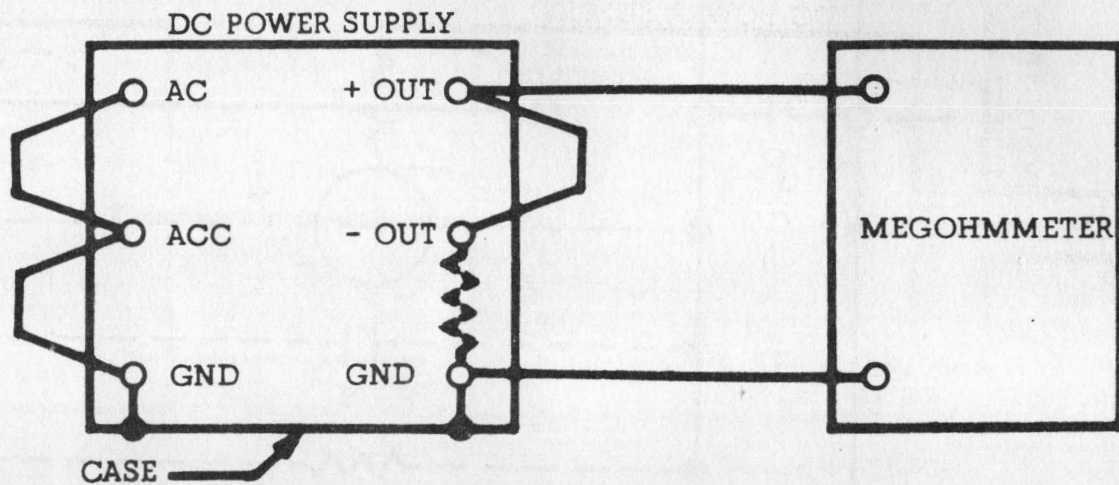

FIGURE 2A MEASURING LEAKAGE RESISTANCE BETWEEN OUTPUT AND GROUND

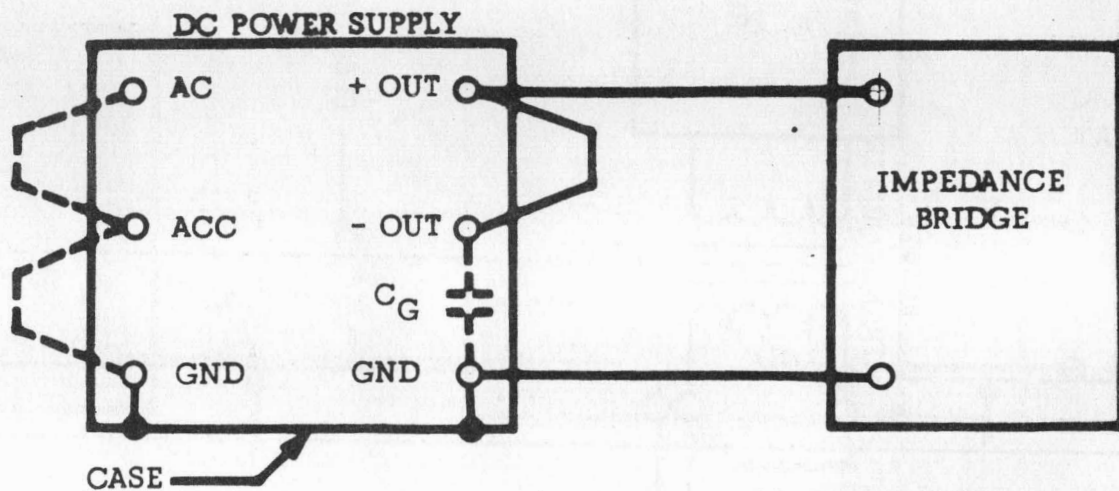

FIGURE 2B MEASURING SHUNT CAPACITANCE BETWEEN OUTPUT AND GROUND

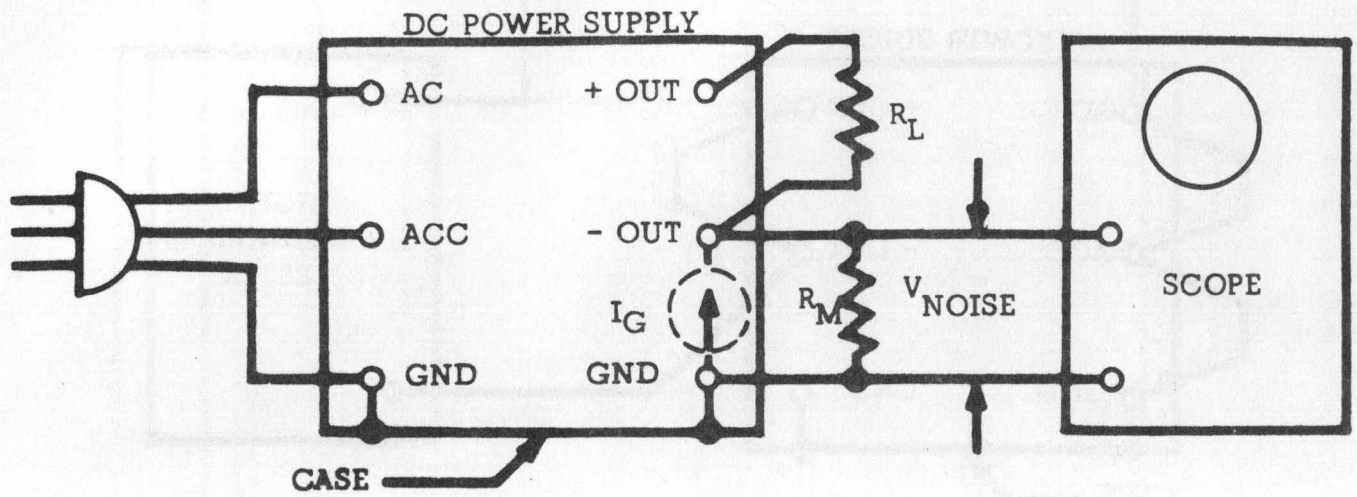

FIGURE 2C MEASURING NOISE CURRENT BETWEEN OUTPUT AND GROUND

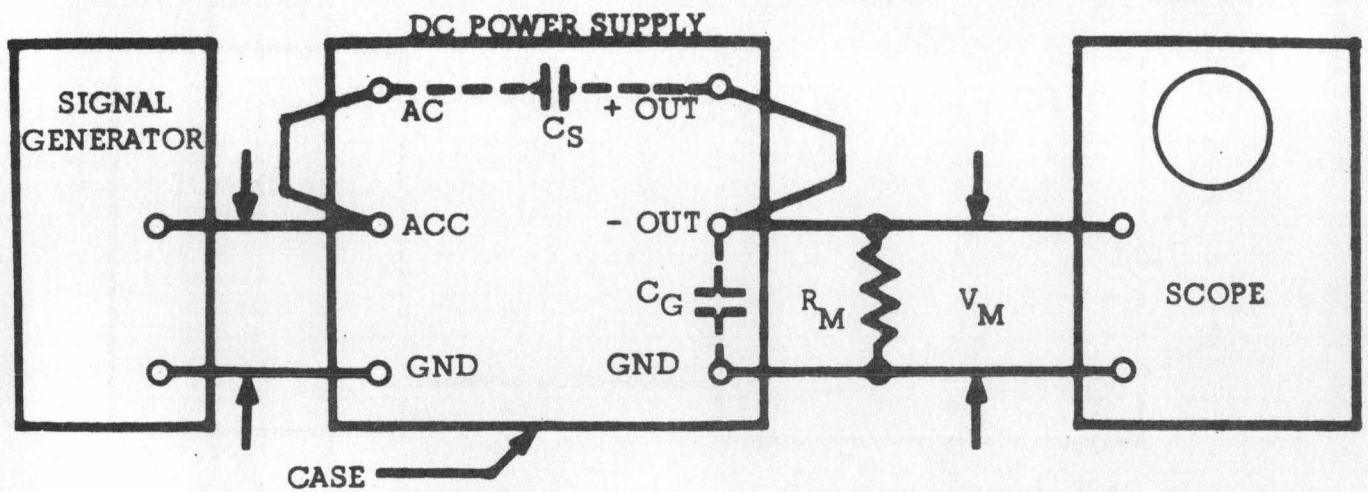

FIGURE 2D MEASURING CAPACITY BETWEEN AC INPUT AND DC OUTPUT

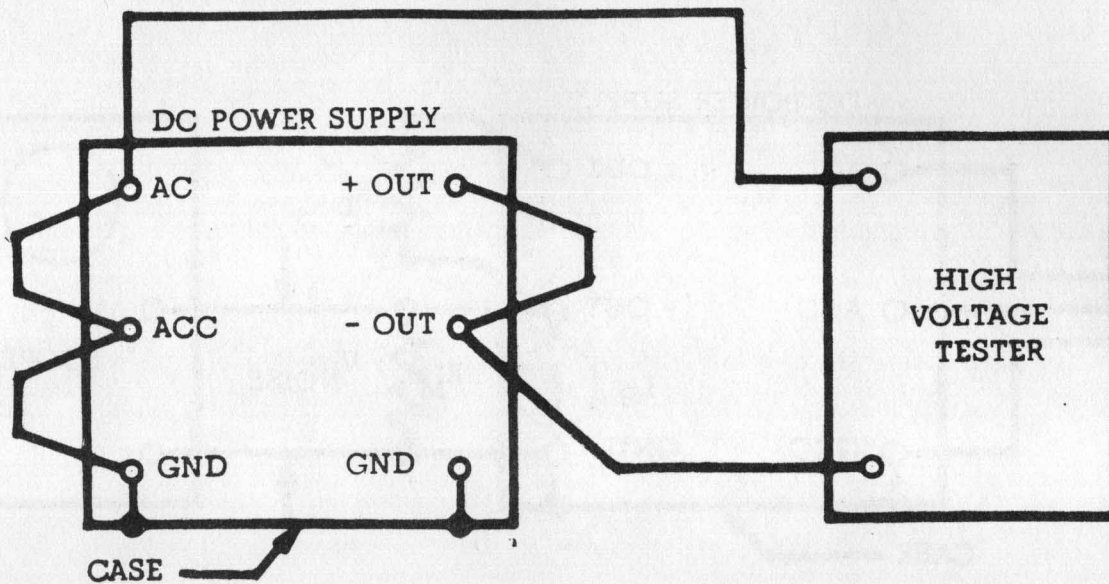

FIGURE 2E MEASURING BREAKDOWN VOLTAGE TO GROUND

